

USER INTERFACE

The user has a display and four buttons for controlling instrument status and programming.

LEDs

cnt	<ul style="list-style-type: none"> slow flashing for parameter programming fast flashing when counting in progress permanently on when counting stopped off when counting stopped, terminated or reset
out1	<ul style="list-style-type: none"> indicates status of output out 1
out2 (EWTS 990 LX)	<ul style="list-style-type: none"> indicates status of output out 2
separation LED	<ul style="list-style-type: none"> separation between hours/minutes/seconds, seconds/hundredths

At start-up the instrument performs a Lamp Test; the display and LEDs flash for a few seconds to check that they are working correctly. The instrument has a menu for setting 3 set points and one for parameter programming.

ACCESSING AND USING MENUS

The resources are arranged in a menu that can be accessed by quickly pressing the "set" button to access the set point setting menu or holding it down for at least 5 seconds to access the parameter programming menu.

To access the contents of each folder indicated by the relevant label, just press the "set" button once.

If you do not use the keyboard for over 15 seconds (time-out) or if you press the "fnc" button once, the last value shown on the display is confirmed and you are taken back to the previous menu level.

SETTING SET POINTS

(see Set Point menu diagram)

To set the Set Points, press the "set" button and quickly release it.

With the EWTS 950 2 set times can be set: "t1", "t2".

With the EWTS 990 3 set times can be set: "t1", "t2", "t3". To set the times, do the following:

- Press the set button and hold it down, "t1" will be displayed and the "cnt" LED will rapidly flash on and off.
- When the button is released, the set time t1 will be displayed. To change it, use the UP key to increase its value or DOWN key to decrease it.
- If the operating mode requires time t2 to be set (F1 = 3, 4 or 5), press the set button again within 5 sec. and "t2" will be displayed.
- When the button is released, the set time t2 will be displayed.

KEYS

Increases value of parameter
Scrolls menus and enables associated function (Par. H31)

UP button



Decreases value of parameter
Scrolls menus and enables associated function (Par. H32)

DOWN button



fnc button esc function
Enables associated function (Par. H33)



set Button
Accesses 3 Set points
Confirms commands
Accesses menus



To change it, use the UP and DOWN buttons.

• If the operating mode requires a third Set point to be set (EWTS 990), (F2 = 3 or 4), press the set button again within 5 sec. and "t3" will be displayed.

• When the button is released, the set time "t3" will be displayed.

To change it, use the UP and DOWN buttons.

The set point setting mode is automatically exited if no set button is pressed for approximately 15 seconds or if the Fnc button is pressed once. The count reached at that time then reappears on the display.

The times can always be set both when counting is or is not in progress.

PROGRAMMING PARAMETERS

NOTE: The menu can only be accessed when counting has stopped.

Access the menu by pressing the 'set' button for at least 5 seconds. The menu structure enables all parameter folders to be divided into two levels. All the level 1 folders can be accessed by entering the password 'PA1'.

You can scroll through the level 1 folders using the 'UP' and 'DOWN' buttons. Press the 'set' button next to the selected label to access the parameters.

Scroll through the parameters in the folder using the 'UP' and 'DOWN' buttons, press 'set' to display the current value of the selected parameter, use the 'UP' and 'DOWN' buttons and set the selected value by pressing 'set'.

To access the level 2 folders in the level 1 'Cnf' folder, select the 'PA2' label, enter the password 'PA2' and confirm with the 'set' button. All the parameters that cannot be changed at level 1 are in this level.

NOTE: level 1 parameters will only be displayed again if you quit the Parameter Programming Menu and repeat the steps for manipulation of level 1 folders.

The steps to follow for manipulation of level 2 parameters are the same as those described for the level 1 structure.

NOTE: we strongly recommend that you switch the instrument off and on again each time parameter configuration is changed in order to prevent malfunctioning of the configuration and/or ongoing timings.

PASSWORD

Passwords "PA1" and "PA2" allow level 1 and level 2 parameters to be accessed. There are no passwords in the standard configuration.

To enable them (value <>0) and assign them the desired value, access the "Programming" menu in the "diS" folder. If passwords are enabled, they will be requested:

- PA1 when entering the Programming menu (see the "Programming Menu" section);
- PA2 in the "Cnf" folder containing the level 1 parameters.

USING THE COPY CARD

The Copy Card is an accessory connected to the TTL serial port used for quick programming of the unit parameters (upload and download parameter map to one or more units of the same type). Operations are described below:

Fr-Format (level 1-2 parameter)

This command can be used to format the copy card. This operation **must** be performed when it is used for the first time or used with models that are not compatible.

Warning: when the copy card has been programmed, all the data entered is cancelled when the "Fr" parameter is used. This operation cannot be undone.

UL-Upload

This operation unloads the programming parameters from the instrument.

dL-Download

This operation downloads the programming parameters to the instrument.

NOTE:

- **UPLOAD: instrument** —> **Copy Card**
- **DOWNLOAD: Copy Card** —> **instr.**

These operations are performed by accessing the folder with the “FPr” label and selecting the “UL”, “dL” or “Fr” commands. The operation is confirmed by pressing the “set” button. If the operation is successful, a “y” is displayed whereas if it is unsuccessful an “n” will be displayed.

Download “from reset”

Connect the copy card with the instrument OFF. When the instrument is switched on, the programming parameters will be downloaded. When the lamp test has been completed, the following are displayed for about 5 seconds:

- label dLY if copy operation is successful
- label DLn if operation fails

PLEASE NOTE:

- after downloading, the instrument will work with the parameter map settings that have just been downloaded.

DISTANCE-MANAGED SYSTEMS

The Televis remote control systems can be connected using the TTL serial port (the TTL-RS 485 BUS ADAPTER 130-150-350 interface module must be used). To configure the instrument to do this, you need to access the “Add” folder and use the “dEA” and “FAA” parameters.

KEYBOARD LOCKED

Keyboard operating can be locked by programming the “Loc” parameter (see folder with “dis” table). If the keyboard is locked you can access the Programming Menu by pressing the “set” button. The set point can also be displayed.

OPERATING**COUNT COMMANDS**

Counting is enabled/disabled using the fnc button on the front keypad (configured as START/STOP, par H33=1), or the CNT EN input.

Counting is reset using the RES input or the button configured as ‘reset’.

Operation of the ‘esc’ button on the front keypad configured as START/STOP and the CNT EN input is controlled by the status of the 2 parameters P10 and P09 respectively (see parameter table). The RES input always stops and resets counting and also has priority over the other commands.

Whilst the reset function is active, counts cannot be started. The rLoc label is displayed (with rapid flashing) rather than the normal display. Parameter P08 controls device operating in the event of a power failure (see parameter table).

When the instrument is able to continue counting even if there is a power failure, during counting in these conditions, the only active command is the RESET com-

mand that can only be enabled using the ‘fnc’ button (configured for resetting, par H33=2). Counting cannot therefore be reactivated after being stopped when the instrument is battery powered.

DISPLAY

The SET/CNT LED is used to indicate:

- the input being programmed (fast flashing)
- counting in progress (slow flashing)
- counting stopped before ending (permanently on)
- counting terminated and reset status (off).

After resetting, 0000 is displayed if the up counting mode is set (par. P07=1) or the set point value set if the down counting mode is set (par. P07=2) During counting the value of the time that elapses, up or down, will be displayed. THE ‘ddd’ parameter can be used to display the t3 time, up or down. If the back-up mode is set to continue counting even if there is a power failure (par P08=2) the 2 central LEDs remain permanently on if counting has stopped, there is a power-down or an external battery is connected. If counting was in progress the two LEDs flash once a second while the display is off.

STAND-BY CONTROLLER

The Stand-by controller can be enabled using the digital input if it is suitably configured (H11-12), or the specially programmed button (H31, 32, 33). The H08 parameter can be used to select the Stand-by operating mode:

- H08=0: In off mode the display stays on and all controllers are disabled.
- H08=1: In off mode the display is switched off and all controllers are disabled.
- H08=2: In off mode “OFF” appears on the display and all controllers are disabled. Each time the device is switched off the cycle times are reset.

TECHNICAL DATA

Front protection: IP65.

Casing: PC+ABS UL94 V-0 resin plastic body, polycarbonate front, thermoplastic resin buttons.

Dimensions: front 74x32 mm, 60 mm depth.

Mounting: on panel, with drilling template 71x29 mm (+0.2/-0.1 mm).

Operating temperature: -5...55 °C.

Storage temperature: -30...85 °C.

Operating and storage ambient humidity: 10...90 % RH (non-condensing).

Display range: 9999 hours, 99 hours and 59 minutes, 99 minutes and 59 seconds, 99 seconds and 99 hundredths.

Digital inputs: 2 voltage-free parameter-configurable digital inputs.

Serial: TTL for Copy Card or connection to TelevisSystem.

Digital outputs (**for EWTS 950 LX**):

- 1 output on SPDT relay 8(3)A 1/2hp 250V~

Digital outputs (**for EWTS 990 LX**):

- first output on SPDT relay 8(3)A 1/2hp 250V~
- second output on SPDT relay 8(3)A 1/2hp 250V~

Accuracy: 3.6 sec/h

Consumption: 3 VA.

External battery not rechargeable: power supply 9V~, instrument absorption with battery power: 9mA.

Power supply: 12 V~/~ or 230 V~ (±10% 50/60 Hz)

Caution: check the power supply specified on the instrument label; for information on relay capacity and power supplies contact the Sales Office).

MECHANICAL ASSEMBLY

The unit has been designed for panel-mounting: Drill a 29x71 mm hole, insert the keyboard and fix it in place with the special brackets provided. Do not assemble the instrument in excessively humid or dirty locations since it is designed to be used in locations with normal levels of pollution. Always make sure that the area next to the unit cooling slits is adequately ventilated.

SETTING SET POINTS — PROGRAMMING MENU

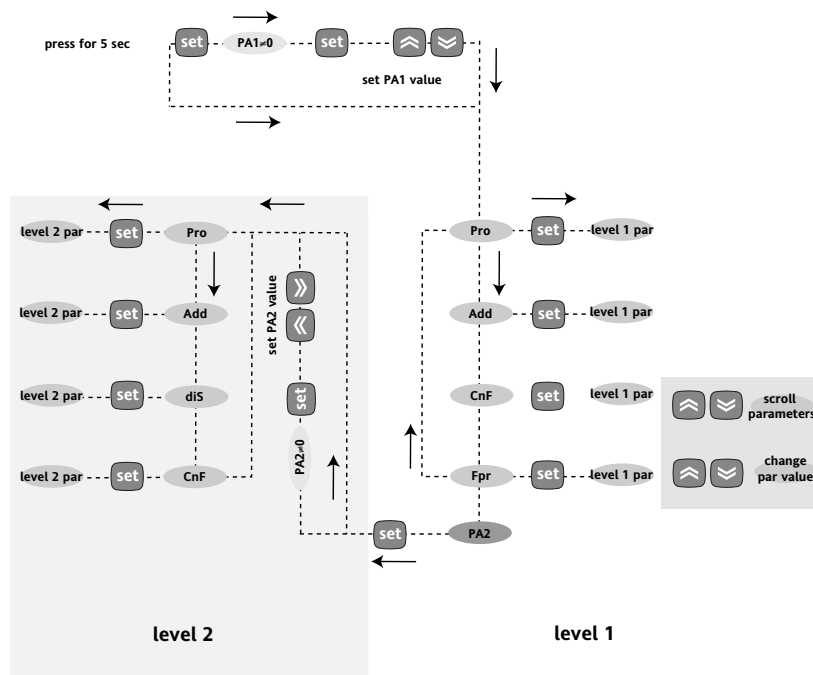
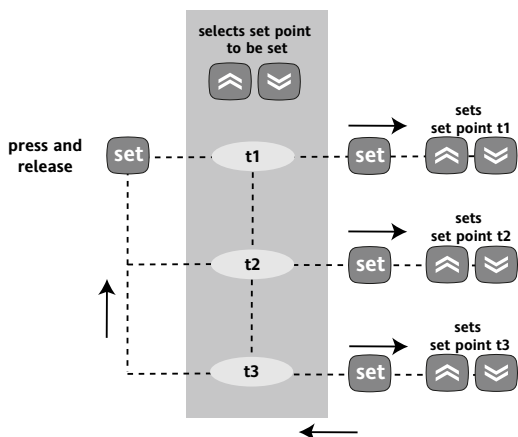

OUTPUT OUT1 OPERATING

The instrument can be programmed using parameter P01 to operate in 5 different modes:

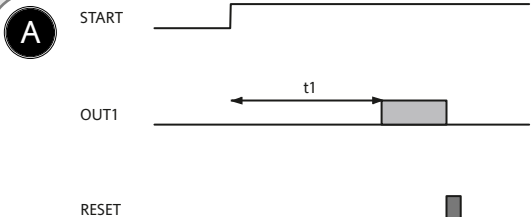

P01=1 — Excitation delay

When the instrument has received the start signal, counting begins and when time “ t_1 ” expires output OUT1 is activated. The output is therefore disabled by the reset signal.

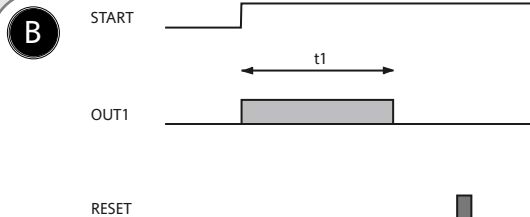

P01=2 — Pass-band excitation

When the instrument has received the start signal, counting begins and output OUT1 is enabled. It is disabled when time “ t_1 ” expires. The output can only be re-activated when the instrument has received the reset signal and another start signal.

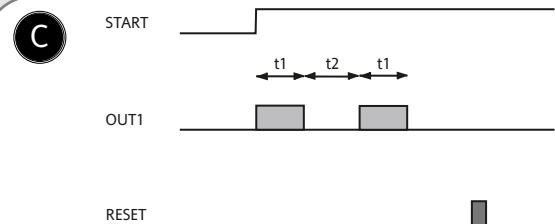

P01=3 — Asymmetric Pause-Start with start = ON

Setting of set point “ t_2 ” is enabled. When the start signal has been given, output OUT1 is enabled for the time set in the first set point (“ t_1 ”). When this period expires, it is disabled and is re-enabled when the time set in the second set point (“ t_2 ”) expires and so on until the stop/reset signal is given. t_1 is therefore the ON time of the output OUT1 whereas t_2 is the OFF time.

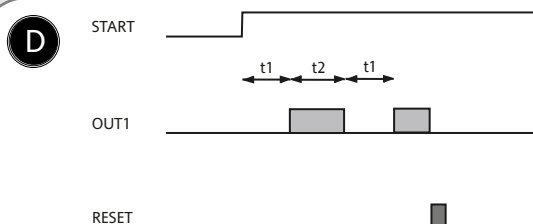

P01=4 — Asymmetric Pause-Start with start = OFF

Setting of set point “ T_2 ” is enabled. When the start signal has been given, output OUT1 remains disabled for the time set in the first set point (“ t_1 ”). When this period expires, it is enabled and is disabled when the time set in the second set point (“ t_2 ”) expires and so on until the stop/reset signal is given. As a result “ t_1 ” is the OFF time of the output OUT1 whereas “ t_2 ” is the ON time.

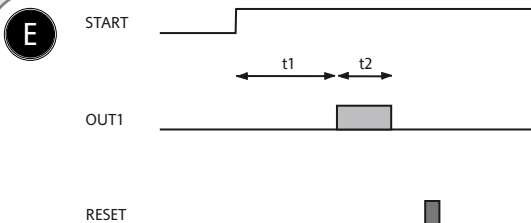

P01=5 - Pause-Start with Pause start and single cycle

It operates in the same way as P01=4 (including enabled set point “ t_2 ”) and the only difference is that only one Pause-Start cycle is performed. When the start signal has been given, output OUT1 remains disabled for the time set in the first set point (“ t_1 ”). When this period expires, it is enabled and is disabled when the time set in the second set point (“ t_2 ”). The cycle can only start up again when the instrument has received the reset signal and another start signal.

OUTPUT OUT2 OPERATING (for EWTS 990 LX model only)

The instrument can be programmed using parameter P02 to operate in 4 different modes:

A **P02=0**
Output OUT2 is always disabled

B **P02=1**
Output OUT2 operates in exactly the same way as OUT1 so that it has a dual output contact

C **P02=2 Output OUT2 operating as instantaneous contact**
The output OUT2 is enabled during counting and remains active until the reset command is given

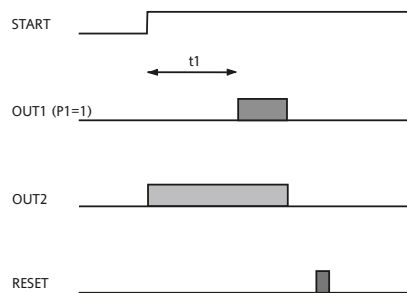

D **P02=3 Operates in same way as P01 (time t1) but time "t3" is absolute**
With P02 = 3 setting of set point "t3" is enabled. It has the same time scale as "t1" and cannot be greater than "t1". When the instrument has received the start signal, it starts counting and operates on output OUT2 in exactly the same way that P01 operates on output OUT1. When setting time "t3", "t3 i" is displayed to indicate that time t3 is independent. As a result, if P01=1, 4 or 5 the output OUT2 operates with the excitation delay function with time "t3"

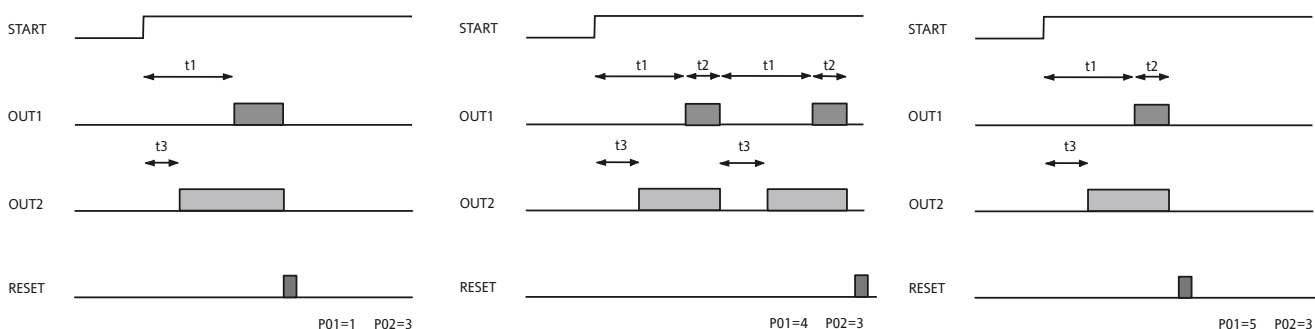

If OUT1 = 2 or 3, output OUT2 operates with the pass-band excitation function with time "t3":

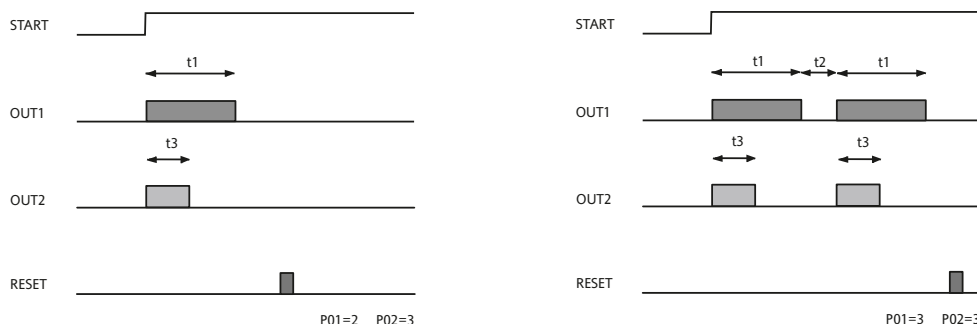

E **P02=4 Operates in same way as P01 (time t1) but with relative time t3 early**
With P02 = 4 setting of set point "t3" is enabled. It has the same time scale as "t1" and cannot be greater than "t1". When the instrument has received the start signal, it starts counting and operates on output OUT2 in exactly the same way that P01 operates on output OUT1. When setting time "t3", "t3 d" is displayed to indicate that time t3 is independent. If P01=2 or 3, output OUT2 operates with the pass-band excitation function with time "t1"-t3":

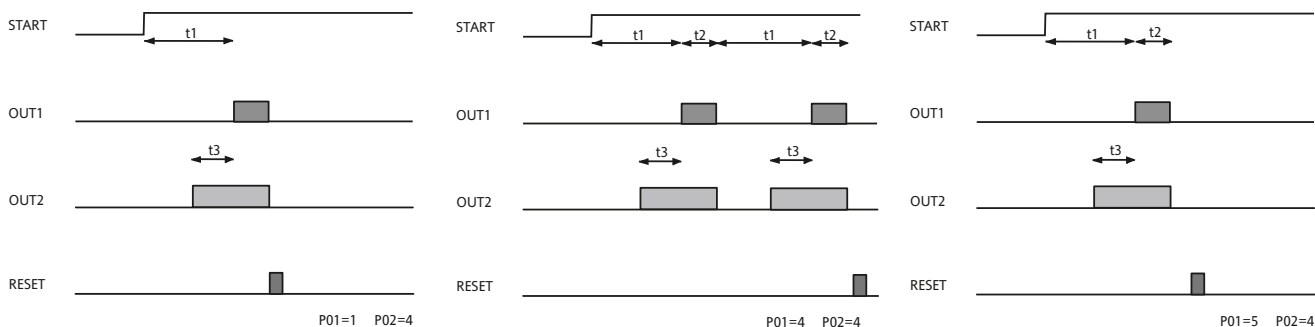

If OUT1 = 2 or 3, output OUT2 operates with the pass-band excitation function with time "t3":

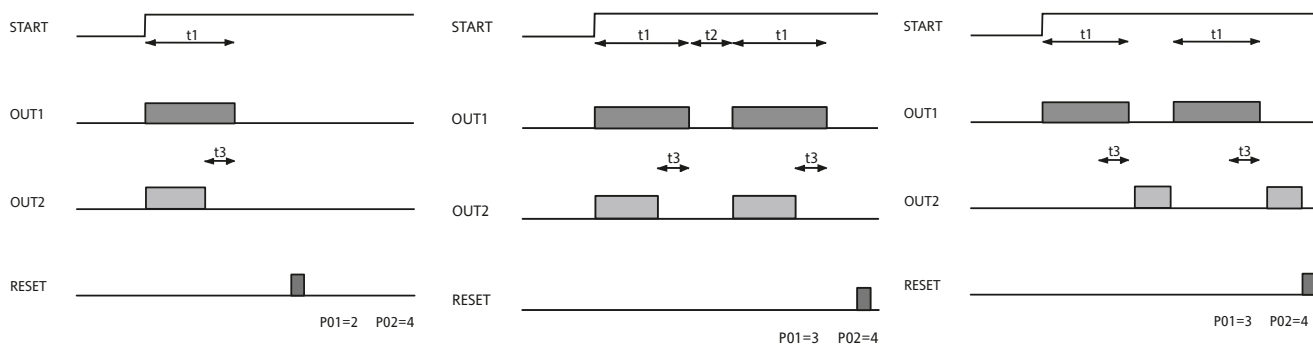

CNT EN OUTPUT OPERATING

The start signal can be given using the START/STOP front button that usually has bistable functionality or the count enabling inputs IN_ST_SP. The IN_ST_SP input can be programmed using parameter P09 to operate in 4 different modes:

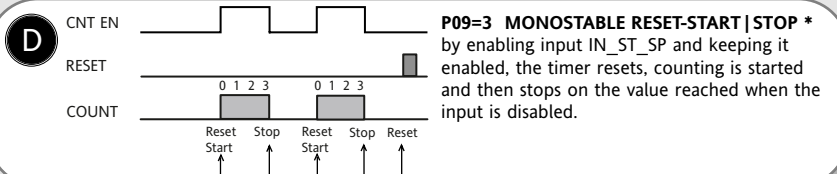
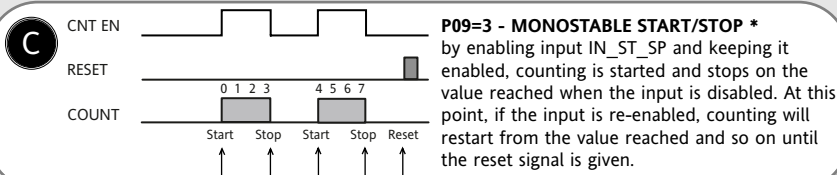
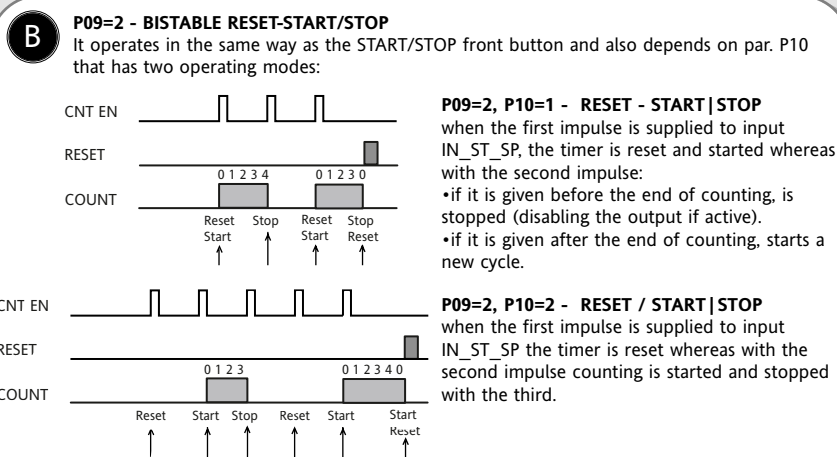
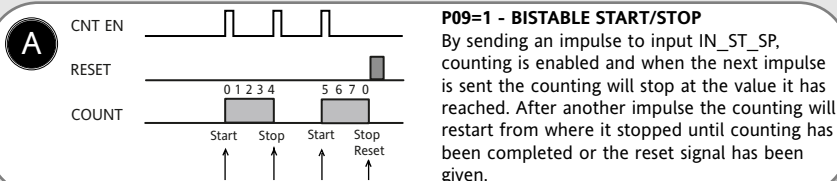

* In this operating mode the START/STOP front button only works as a reset button

ELECTRICAL CONNECTIONS

Warning! Always switch off machine before working on electrical connections.

The instrument has screw terminal blocks for connecting cables with a maximum diameter of 2.5 mm² (only one conductor per terminal block for power connections): for terminal capacity, see the label on the instrument.

The relay outputs are voltage free.

Do not exceed the maximum current allowed. For higher loads, use a suitable contactor.

Make sure that the power voltage complies with the device voltage.

CONDITIONS OF USE

PERMITTED USE

For safety reasons the instrument must be installed and used in accordance with the instructions supplied. Users must not be able to access parts with dangerous voltage levels under normal operating conditions.

The device must be suitably protected from water and dust according to the specific application and only be accessible using special tools (except for the front keypad).

The device can be fitted to equipment for household use and/or similar use in the refrigeration sector and has been tested with regard to safety in accordance with the European harmonized reference standards. It is classified as follows:

- as an automatic electronic control device to be independently mounted as regards its construction;
- as a 1 R type operated control device as regards its automatic operating features;
- as a Class A device as regards the category and structure of the software.

UNPERMITTED USE

The use of the unit for applications other than those described above is forbidden. It should be noted that the relay contacts supplied with the device are functional and therefore exposed to potential faults. Any protection devices required to comply with product requirements or dictated by common sense due to obvious safety reasons should be installed externally.

DISCLAIMER

This document is exclusive property of Eliwell and cannot be reproduced and circulated unless expressly authorized by Eliwell.

Although Eliwell has taken all possible measures to guarantee the accuracy of this document, it declines any responsibility for any damage arising out of its use.

The same applies to any person or company involved in preparing and writing this document. Eliwell reserves the right to make any changes or improvements without prior notice and at any time.

RESPONSIBILITY AND RESIDUAL RISKS

Eliwell shall not be liable for any damages deriving from:

- installation/use other than that prescribed and, in particular, which does not comply with the safety standards specified in the regulations and/or those given herein;
- use on boards which do not guarantee adequate protection against electric shock, water or dust when assembled;
- use on boards which allow dangerous parts to be accessed without the use of tools;
- tampering with and/or alteration of the product;
- installation/use on boards that do not comply with the standards and regulations in force.

PAR.	DESCRIPTION	RANGE	DEFAULT	VALUE	LEVEL	U.M.
t1	Set Point "t1"	0...9999	1		/	hours/min/sec
t2	Set Point "t2"	0...9999	1		/	hours/min/sec
EWTS 990 LX only						
t3	Set Point "t3"	0...9999	1		/	hours/min/sec

Programming — Pro label	P01	Output OUT1 operating mode; establishes operating of output OUT1 for counting: 1=excitation delay; 2=pass-band excitation 3=asymmetric oscillator (Pause-Start) start off 4=asymmetric oscillator (Pause-Start) start on 5=single cycle pause-start	1...5	1		1-2	num
	EWTS 990 LX only						
	P02	Output OUT2 operating mode; establishes operating of output OUT2 for counting: 0=output not operating by enabling input CNT EN and keeping counting active; 1=operating as OUT1; 2=active during counting it is disabled; 3=Same as OUT1 with time 2 independent; 4=Same as OUT1 with time 2 independent	0...5	0		1-2	num
	P03	Time scale t1; establishes unit of measurement of time t1 (and t3 if enabled): 1=hours (9999) 2=hours-min (99 hours/59 min) 3=min-sec (99 min/59 sec) 4=sec-hundredths (99 sec/99 hundredths)	1...4	1		1-2	num
	P04	Time scale t2; establishes unit of measurement of time t2: 1=hours (9999) 2=hours-min (99 hours/59 min) 3=min-sec (99 min/59 sec) 4=sec-hundredths (99 sec/99 hundredths)	1...4	1		1-2	num
	P05	Time t1 maximum set point; establishes the maximum value of the 2 most significant figures that can be set for set point t1	0...99	99		1-2	hours/min/sec
	P06	Time t2 maximum set point; establishes the maximum value of the 2 most significant figures that can be set for set point t2	0...99	99		1-2	hours/min/sec
	P07	Counting mode; establishes if the counting must be UP or DOWN: 1=UP 2=DOWN	1...2	1		1-2	num
	P08	Back-up mode; establishes the behaviour of the machine if there is a power failure: 1=stops counting and stores the value 2=continues counting (only with battery present) 3=resets counting	1...3	1		1-2	num
	P09	CNT EN input operating mode; establishes operating of count enabling input: 1=bistable START STOP 2=bistable RESET-START STOP 3=monostable START/STOP 4=monostable RESET-START STOP	1...4	1		1-2	num
P10	START/STOP button operating mode: 0=non operational 1=RESET-START/STOP 2=RESET START/STOP 3=RESET only	0...3	1		1-2	num	
Communication Add label	dEA (1)	Device address in family	0...14	0		1-2	num
	FAA (1)	Device family	0...14	0		1-2	num
Programming Pro label	LOC (2)	Keyboard locked (blocks activation of primary functions) 0=n=keyboard enabled 1=y=keyboard locked	n/y	n		1-2	flag
	PA1	Contains the password for access to level 1 parameters. Enabled if not 0	0...255	0		1-2	num
	PA2	Contains the password for access to level 2 parameters. Enabled if not 0	0...255	0		2	num
	EWTS 990 LX only						
ddd	display of fundamental state; determines display when instrument starts up: 0=t1/t2 1=t3	0/1	0		1-2	flag	

NOTE: The symbol 1-2 indicates the parameters that are displayed at both menu levels At level 2 the folders will only display level 2 parameters.

PAR.	DESCRIPTION	RANGE	DEFAULT	VALUE	LEVEL	U.M.	
Programming — CnF label	H02	Quick enabling time using configured buttons.	0...15	1		2 sec	
	H08	Stand-By operating mode 0=display remains on and controllers are disabled 1=display is turned off and controllers disabled 2="OFF" is displayed and controllers are disabled	0/1/2	2		2 num	
	H11 (3)	Configurability of digital inputs/polarity 0=disabled 1=CNT enable (reads front buttons) 2=RESET (reads level) 3=Stand By	-3...3	-1**	**WARNING: H11 & H12 MUST BE ALWAYS DIFFERENT	2	num
	H12 (3)	Configurability of digital inputs/polarity Same as H11	-3...3	-2**		2	num
	H21	Digital output 1 configurability: 0=disabled; 1=out1; 2=out2 (for EWTS 990 LX only)	0...2	1		2	num
	EWTS 990 LX only						
	H22	Digital output 2 configurability: Same as H21	0...2	2		2	num
	H31	UP button configurability 0=disabled 1=START/STOP 2=RESET 3=Stand By	0...3	0		2	num
	H32	DOWN button configurability Same as H31	0...3	0		2	num
	H33	fnc button configurability. Same as H31: in the event of a power failure, the only active command is the RESET command that can only be activated by the 'fnc' button	0...3	1		2	num
	rEL	Device version. Read only parameter	0...65535	- / -		1-2	num
	tAb	Parameter table. Read only parameter	0...65535	/		1-2	num
	Copy Card Fpr label	UL	Transfer of parameter map from instrument to Copy Card	/	/		1-2 /
dL		Transfer of parameter map from Copy Card to ON and OFF	/	/		1-2 /	
Fr (4)		Formatting. Cancels all data on Copy Card	/	/		1-2 /	

NOTES:

- (1) The pair of values dEA and FAA represents the device network address and is indicated as "FF.DD" (where DD=dEA and FF=FAA).
- (2) When the keyboard lock is enabled the Set Point can only be displayed using the "set" button and the password-protected parameter programming menu accessed.
- (3) CAUTION: positive or negative values change polarity, positive values: active input when the contact is closed; negative values: active input when contact is open.
- (4) If the Fr parameter is used, the data previously stored on the Copy Card will be permanently lost. **This operation cannot be undone**

CONNECTIONS

TERMINALS

1-2	N.O. relay output OUT 1 see par. H21
1-3	N.C. relay output OUT 1 see par. H21
4-5*	N.O. relay output OUT 2 see par. H22
6-7**	Power supply
8-9	Digital input D.I.1
8-10	Digital input D.I.2
8-11	External battery 9V~
A	TTL input for Copy Card and connection to TelevisSystem

* for EWTS 990 LX models only

** Available in 2 different power supplies:
12V~/~ ±10% or 230V~ ±10%

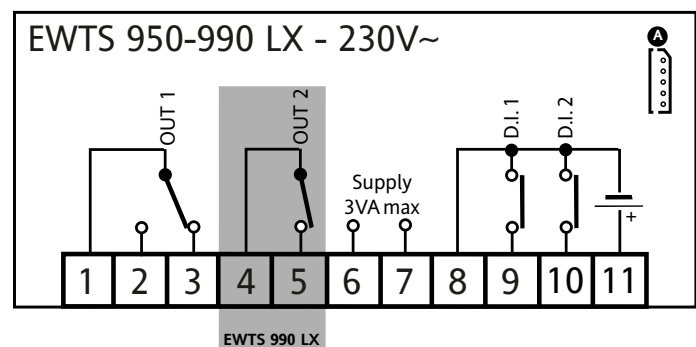
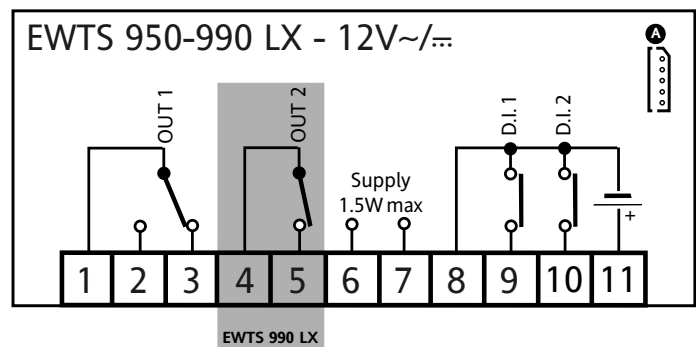

eliwell

Eliwell & Controlli s.r.l.
Via dell'Industria, 15 Zona Industriale Paludi
32010 Pieve d'Alpago (BL) ITALY
Telephone +39 0437 986111
Facsimile +39 0437 989066
Internet <http://www.eliwell.it>

Technical Customer Support:
Email: techsuppeliwell@invensys.com
Telephone +39 0437 986300

Invensys Controls Europe
Part of the Invensys Group
1-05/b eng
cod 9IS43096

