

USER INTERFACE

The user has a display and four buttons for controlling status and programming of the instrument.

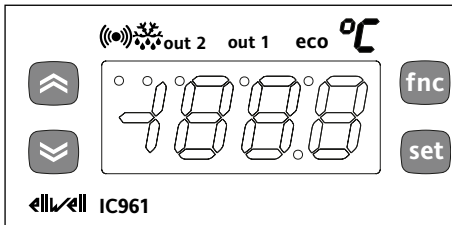

UP button



Scrolls through the menu items
Increases the values

DOWN button



Scrolls through the menu items
Decreases the values

fnc button



ESC function (exit)

Set point button



1-Accesses Machine Status Menu (SET POINT, ACTIVE ALARMS, PROBE READING) and relative labels/values;
1-Accesses Programming Menu (PARAMETERS, COPY CARD) and relative labels/values;
3-Confirms commands

LEDs

Alarm	Defrosting	out2	out1	eco
•ON for active alarm; •blinking for silenced alarm that is still present	•ON when defrosting in progress; •blinking when dripping is in progress	Relay 2 (OUT2) ON for relay on (energized);blinking for protection delay or enabling blocked	Relay 1 (OUT1) ON for relay on (energized); blinking for protection delay or enabling blocked	Set point/ Reduced set point •ON to modify Set-Point; •blinking when reduced set point is entered

ACCESSING AND USING MENUS

The resources are arranged in a menu that can be accessed by pressing and quickly releasing the “set” button (Machine Status menu) or holding down the “set” button for more than 5 seconds (Programming menu). To access the contents of each folder indicated by the relevant label, just press the “set” button once.

You can now scroll through the contents of each folder, modify it or use its functions. If you do not use the keyboard for over 15 seconds (time-out) or if you press the “fnc” button once, the last value shown on the display is confirmed and you return to the previous screen mask.

MACHINE STATUS MENU

(See Machine Status Menu Diagram)

To access the Machine Status menu, press the “set” button and quickly release it The “SP1” label appears.

(If alarms are active, with the exception of faulty probes/probe errors, the “AL” label appears).

By using the “UP” and “DOWN” buttons you can scroll through the other folders in the menu: the folders are indicated below in the order they appear:

- SP1: Set point 1 setting folder or
- AL: alarm folder (if alarms present, with exception of faulty probes/probe errors);
- SP2: Set point 2 setting folder.
- Pb1: probe 1 value folder;

MACHINE STATUS MENU DIAGRAM

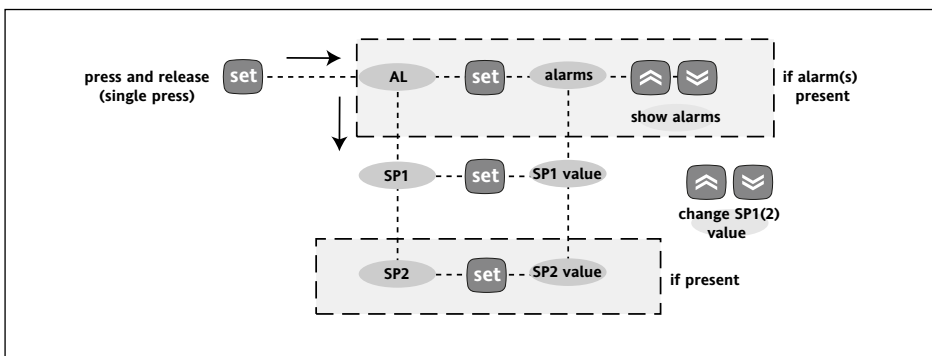

HOW TO SET THE SET POINT

Access the “Machine Status” menu, press the “set” button and quickly release it. The “SP1” folder label appears. (To set Set point 2 press the “UP” and “DOWN” buttons until “SP2” appears). To display the Set point 1 (2) value, press the “set” button again. The Set point value appears on the display. To change the Set point 1 (2) value, press the “UP” and “DOWN” buttons within 15 seconds. If parameter LOC = y the Set points cannot be changed.

HOW TO DISPLAY THE TEMPERATURE READ BY PROBE

If you press the “set” button when the corresponding label appears, the value of the probe associated with it is displayed.

ALARM PRESENT?

If an alarm condition exists when the Machine Status menu is accessed, the “AL” folder label appears. chge will include the alarm codes. (see section on “Diagnostics”).

The folders are present according to the presence and configuration of the associated resource.

HOW TO ACTIVATE MANUAL DEFROSTING

To activate the defrost cycle manually,
1- press the button for 5 seconds (if H11=1);
2- use special functions in the FnC folder (see).

If there are not the right conditions for defrosting the display will flash three (3) times to indicate that the operation will not be performed.

HOW TO LOCK THE KEYBOARD

Keyboard operating can be locked by programming the “Loc” parameter (see folder with “dis” table). If the keyboard is locked you can only access the Programming MENU (see) You can also display but NOT modify the Set point; functions activated using the buttons (e.g. manual defrosting) are NOT allowed.

*FNC FUNCTION FOLDER

The FnC folder (last folder visible from the Programming Menu, level 1) contains the following functions. They are activated using the “set” button

If the unit is switched off, the function labels go back to their default status.

Function	Function label ACTIVE	Function label NOT ACTIVE
Manual defrost	dEF	dEF **
Reduced set point	*OSP	SP
Controls blocked	boN	boF
Heating control counter reset	rEH	rEH
Cooling control counter reset	rEC	rEC

* the dEF LED blinks
** the dEF LED does not BLINK

HEATING-COOLING INPUT

If parameter H11=6 (H/C mode) machine operating can be modified, i.e.:

With parameter H14 you can set a start-up delay and with parameter H11 you can set the polarity.

NOTE: The ‘-’ sign indicates that the input is activated when the contact is open. The ‘+’ sign indicates that the input is activated when the contact is closed. Machine operating can be modified from Heating to Cooling mode and vice versa from Cooling to Heating mode.

Input status	Machine operating
Open	Controller 1 (cooling)
Closed	Controller 2 (heating)

***Please Note:** default parameter setting for H02 =2--> Neutral Zone regulation;
in this case The Heating-Cooling controller CANNOT be set

DIGITAL INPUT CONFIGURATION

The digital input can be configured through parameter H11=5 (see also Heating Cooling Input).

This function can be used to activate the relay if it was de-energized or energize it if this was not the case. The status is stored so that the unit operates correctly in the event of a black-out; if this is the case, the relay reflects the status of the digital input.

NOTE: The meaning of the Digital Input (D.I.) must not change: for example, by activating the relay from the D.I. and deactivating using the keyboard, the relay does not change status if the D.I. is repositioned since it has been deacti-

Par.	Description	Range
H11	Configurability digital inputs:	-6...6 (6 = H/C Mode)

PLEASE NOTE: if H11=5 (external alarm) the Digital Input affects on Alarm LED but not on the relays H/C.

NOTE: The technical characteristics in this document concerning measurements (range, accuracy, resolution, etc.) refer to the instrument in the strictest sense and not to any accessories provided such as probes, for example. This means that an error introduced by the probe is added to any error that is in the instrument.

TECHNICAL DATA

Front protection: IP65.

Casing: PC+ABS UL94 V-0 resin plastic body, polycarbonate front, thermoplastic resin buttons.

Dimensions: front panel 74x32 mm, depth 59 mm (terminals excluded).

Mounting: on panel, with drilling template 71x29 mm (+0.2/-0.1 mm).

Operating temperature: -5...55 °C.

Storage temperature: -30...85 °C.

Usage ambient humidity: 10...90 % RH (non-condensing).

Storage ambient humidity: 10...90% RH (non-condensing).

Display range:

- NTC probe: -50.0...110.0°C (-58...230°F);

- PTC probe: -55.0...140.0°C (-67...284°F) on display 3 1/2 digits + sign.

Analogue input: one PTC or NTC input (parameter selectable).

Digital input: 1 voltage-free parameter-configurable digital input.

Serial: TTL for connection to Copy Card.

Digital outputs: 2 outputs on relays:

- (Out1) 1 output on SPDT relay 8(3)A 1/2 hp 250V~,

- (Out2) 1 output on SPST relay 8(3)A 1/2 hp 250V~,

(for relay capacity, see instrument label).

Buzzer output: only in certain models.

Measurement range: from -55 a 140 °C.

Accuracy: better than 0.5% of bottom scale + 1 digit.

Resolution: 0.1°C (0.1°F up to +199.9°F; 1°F above).

Consumption: 3 VA max.

Power supply: 12V~/~, 12-24V~, 12-36V~ ±10%, 115/230V~ ±10% 50/60Hz.

Warning: check the power supply specified on the instrument label; for information on relay capacity and power supplies contact the Sales Office.

CONDITIONS OF USE

Permitted use

For safety reasons the instrument must be installed and used in accordance with the instructions supplied. Users must not be able to access parts with dangerous voltage levels under normal operating conditions.

The device must be protected from water and dust depending on the specific application and only be accessible by using special tools. (except for the front panel).

device is ideally suited for use on household appliances and/or similar refrigeration equipment and has been tested with regard to safety in accordance with the European harmonized reference standards. It is classified as follows:

- for its construction, as an automatic electronic control device to be independently mounted;
- for its automatic operating features, as a 1 B-type operated control type device;
- as a Class A device in relation to the category and structure of the software.

Unpermitted use

The use of the unit for applications other than those described is forbidden. It should be noted that the relay contacts supplied with the device are functional and therefore exposed to potential faults. Any protection devices required to comply with product requirements or dictated by common sense due to obvious safety reasons should be installed externally.

USING COPY CARD

The Copy Card is an accessory connected to the TTL serial port that is used for quick programming of the unit parameters (upload and download parameter map to one or more units of the same type). Operations are described below:

Fr-Format

This command is used to format the copy card. This is **necessary** if

- it is used for the first time,
- it is used with models that are not compatible,
- after use with a specific model, another model must be connected.

Attention: when the copy card has been programmed using the “Fr” parameter all the data entered is cancelled. This operation cannot be undone.

UL-Upload

This operation unloads the programming parameters from the instrument.

dL-Download

This operation downloads the programming parameters to the instrument.

NOTE:

- **UPLOAD:** instrument → Copy Card
- **DOWNLOAD:** Copy Card → instrument.

The operations are performed by accessing the folder identified by the “FPr” label and selecting the “UL”, “dL” or “Fr” commands. The operation is confirmed by pressing the “set” button. If the operation is successful, a “y” is displayed whereas if it is unsuccessful an “n” will be displayed.

Download “from reset”

Connect the copy card with the instrument OFF. When the instrument is switched on the programming parameters will be downloaded into the copy card; when the lamp test has been completed, the following appear on the display for about 5 seconds:

- label dLY if copy operation is successful
- label DLn if operation fails

PLEASE NOTE:

- after downloading the instrument will work with the parameter map settings that have just been downloaded.

PROGRAMMING MENU

(See Programming Menu Diagram)

1) Displaying level 1 parameters

To access the Programming menu, hold the “set” button for more than 5 seconds.

Level 1 parameters can be protected by a PASSWORD* (defined by parameter DIS/PA1) If the PASSWORD is enabled, the label “PA1” will appear when you access the **Programming Menu**; press the “set” button and the value “0” will appear; enter the password using the “UP”/“DOWN” buttons and press the “set” button again. This allows you to access the level 1 parameters. The first folder that appears is “CP”.

Use the “UP” and “DOWN” buttons to scroll through the other folders; **the folders will only display level 1 parameters.**

NOTE: at this level level 2 parameters are NOT visible even if NOT password-protected.

2) Displaying level 2 parameters

Go to the “CnF” folder in the Programming Menu and scroll down the parameters until you reach the PA2 label. By pressing and releasing the “set” button you will enter the level 2 parameters

and the “CP” label of the first folder in the programming menu will appear.

The level 2 parameters can be protected by a second PASSWORD* (defined by parameter DIS/PA2)

(NOTE: not to be confused with the PA2 label in the “CnF” folder).

If the PASSWORD is enabled, the label “PA2” will appear in CnF/PA2 when you access the **Programming Menu**; press the “set” button and the value “0” will appear; enter the password using the “UP”/“DOWN” buttons and press the “set” button again. This allows you to access the level 2 parameters. The first folder that appears is “CP”.

NOTE: At this level the folders will only display all the level 2 parameters. Therefore level 1 parameters will only be visible if you quit the Programming Menu and repeat procedure 1).

NOTE: It is strongly recommended that the unit is switched off and on again each time parameter configuration is changed in order to prevent malfunctioning of the configuration and/or ongoing timings (compulsory for selection of probe type and count parameters).

***PASSWORD**

Passwords “PA1” and “PA2” allow level 1 and level 2 parameters to be accessed. In the standard configuration passwords are not present. To enable them (value ≠0) and assign them the desired value, access the Programming menu in the “dis” folder. If passwords are enabled, they will be requested:

- PA1 when entering the Programming menu (see the “Programming Menu” section);
- PA2 in the “Cnf” folder containing level 1 parameters.

RESPONSIBILITY AND RESIDUAL RISKS
Eliwell & Controlli s.r.l. shall not be liable for any damages deriving from:

- installation/use other than that prescribed and, in particular, which does not comply with the safety standards specified in the regulations and/or those given herein;
- use on equipment that does not guarantee adequate protection against electric shock, water or dust when assembled.
- use on equipment that allows dangerous parts to be accessed without the use of tools;
- tampering with and/or alteration of the product;
- use on equipment that does not comply with the standards and regulations in force.

PROGRAMMING MENU DIAGRAM

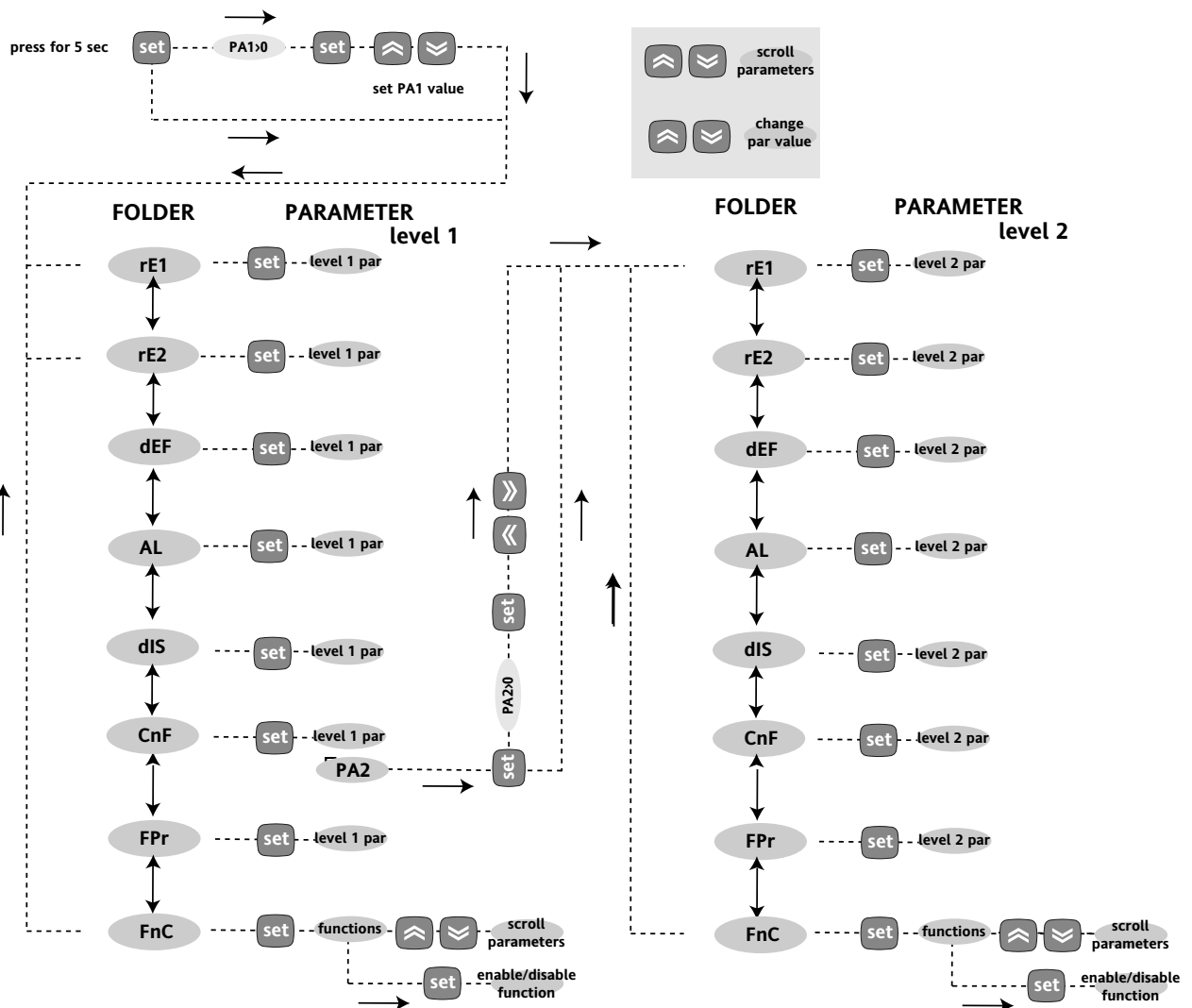

ELECTRICAL WIRING

Attention! Always switch off machine before working on electrical connections.

The instrument has screw terminals for connecting electrical cables with a diameter of 2,5 mm² max. (only one conductor per terminal for power connections): for terminal capacity, see the label on the instrument.

The relay contacts are voltage free. Do not exceed the maximum current allowed. For higher loads, use a suitable contactor.

Make sure that the power voltage complies with the device voltage. The sensor has no connection polarity and can be extended using an ordinary bipolar cable (note that extending the probe may affect the electromagnetic compatibility (EMC) of the instrument: special care must be used when wiring. Probe cables, power supply cables and the TTL serial cable should be kept separate from power cables.

MECHANICAL MOUNT

The unit has been designed to be panel-mounted: Drill a 29x71 mm hole, insert the keyboard and fix it in place with the special brackets provided. Do not assemble the keyboard in excessively dirty and/or dirty locations because it is designed to be used in locations with normal degrees of pollution. Always make sure that the area near the cooling slits of the device is adequately ventilated.

HEATING/COOLING INPUT DIAGRAM

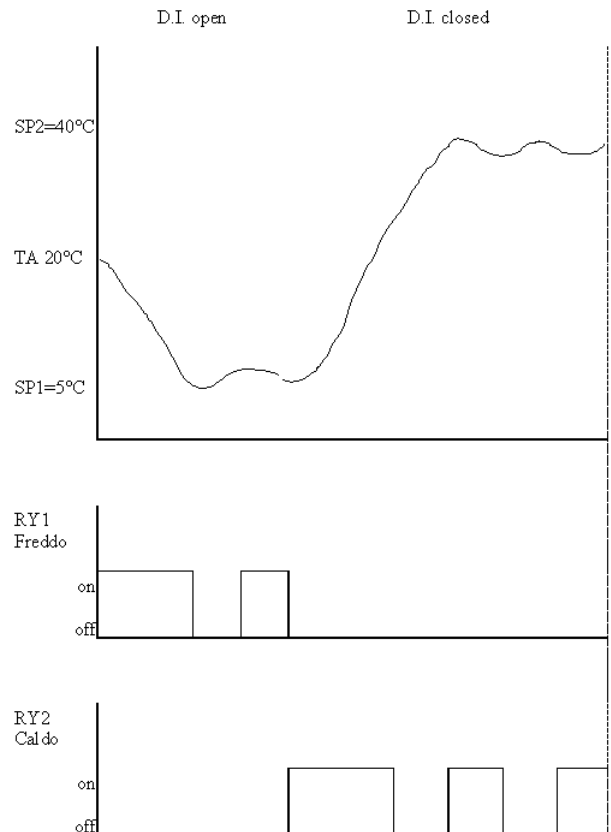

DUTY CYCLE DIAGRAM

On1(2) OF1(2) parameters programmed for Duty Cycle

On1 (On2)	OF1 (OF2)	Controller output
0	0	OFF
0	>0	OFF
>0	0	ON
>0	>0	dc

An error condition in probe 1 (regulation) leads to:

- E1 code appearing on display
- the controller being activated as indicated by the "On1(On2)" and "OF1(OF2)" parameters if programmed for the duty cycle

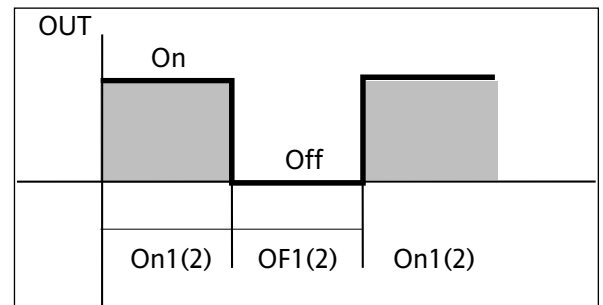

ON-OFF DIAGRAM

HC1	HC2	H01	type of regulation
H	C	0	independent set points
H	C	1	dependent set points
-	-	2*	Neutral Zone (or window)

NOTE: examples with HC1=H and HC2=C

***Please Note: default parameter setting for H02 =2--> Neutral Zone regulation; in this case The Heating-Cooling controller CAN-NOT be set**

independent ON-OFF regulation diagram.
The two outputs regulate as though they are completely independent

1

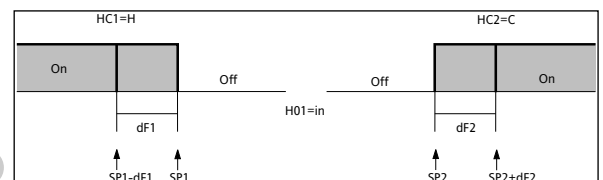

dependent ON-OFF regulation diagram.
The set point 2 SP2 regulates according to SP1

2

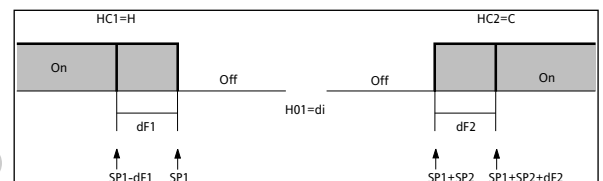

ON-OFF regulation diagram Neutral Zone (or window).
NOTE: if dF1 and dF2 are both =0 the outputs are deactivated when SP1 is reached

3

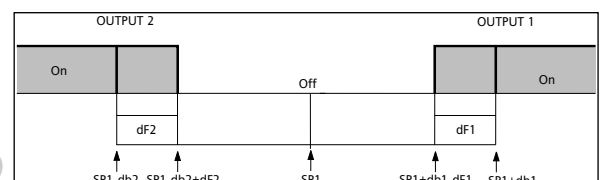

DIAGNOSTICS

The alarm condition is always signalled by a buzzer (if present) and the alarm ((●)) LED. The alarm signals from the

- control probe that measures values outside the nominal reading range
- control probe faulty/shorted/open probe appears directly on the instrument display as E1.

Note: to prevent false alarms, the error condition must persist for more than 10 seconds. An error condition in probe 1 (regulation) leads to:

- E1 code appearing on display
- the controller being activated as indicated by the "On1(On2)" and "OF1(OF2)" parameters if programmed for the duty cycle or... (see **DUTY CYCLE diagram**)

MAXIMUM AND MINIMUM TEMPERATURE ALARM

If an alarm condition occurs and alarm exclusion times are not in progress (see alarm exclusion parameters), the fixed alarm icon is turned on.

This type of alarm does not affect the regulating in progress.

Alarms are considered as absolute (Abs, default) values or as values related to the Set point (Rel, the distance from the Set point itself) and based on the Att parameter. If the alarms are relative (Att=rEL), the parameter HA1(2) is set to positive values and LA1(2) to negative values.

This alarm condition can be displayed in the "AL" folder with the labels "AH1(2)-AL1(2)".

EXTERNAL ALARM

The device can also control an external alarm, i.e. from a digital input. If the digital input is enabled, the alarm control is activated by programming and remains enabled until the next time the digital input is deactivated. The alarm is signalled by turning on the fixed alarm icon, and deactivating the relay (if specified by the "H11=5" parameter). This alarm condition can be displayed in the "AL" folder using the "EA" label. The alarm can be silenced; even if the alarm icon starts blinking, controls stay locked until the next time the digital input is deactivated.

DISCLAIMER

This document is the exclusive property of Eliwell & Controlli s.r.l. and cannot be reproduced and circulated unless expressly authorized by Eliwell & Controlli s.r.l..

Although Eliwell & Controlli s.r.l. has taken all possible measures to guarantee the accuracy of this document, it declines any responsibility for any damage arising out of its use.

The same applies to any person or company involved in preparing and writing this manual. Eliwell & Controlli s.r.l. reserves the right to make any changes or improvements without prior notice and at any time.

Table of faulty probes

DISPLAY	FAULT
E1	Faulty probe 1 (thermostat control)

Alarm table

DISPLAY	ALARM
AH1	High temperature alarm (referring to room probe or probe 1)
AL1	Low temperature alarm (referring to room probe or probe 1)
Ad2	Defrosting timed out
EA	External alarm
Opd	Door Open Alarm

Press any button to silence the alarm. In this case the LED will start to blink.

Max/Min. Alarm Diagram (minimum and maximum temperature)

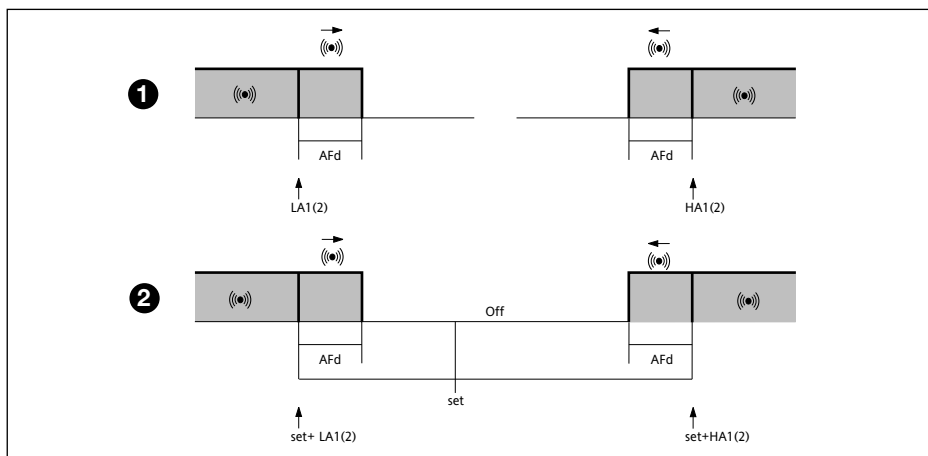

The maximum temperature alarm occurs when the probe temperature is:

- (1) higher than or equal to HA1(2) if Att=Ab(solute)
- (2) higher than or equal to set point + HA1(2) if Att=rEL(ative)

- if Att=Abs(olute) HA1(2) must be with a sign;
- if Att=rEL(ative) HA1(2) must be only positive.

The minimum temperature alarm occurs when the probe temperature is:

- (1) lower than or equal to LA1(2) if Att=Ab(solute)
- (2) lower than or equal to Set point + LA1(2) if Att=rEL(ative)

- if Att=Abs(olute) LA1(2) must be with a sign;
- if Att=rEL(ative) LA1(2) must be only negative.

The maximum temperature alarm back swing occurs when the probe temperature is:

- (1) lower than or equal to HA1(2) - AFd if Att=Ab(solute)
- (2) lower than or equal to set point + HA1(2) - AFd if Att=rEL(ative)

The minimum temperature alarm back swing occurs when the probe temperature is:

- (1) higher than or equal to LA1(2) + AFd if Att=Ab(solute)
- (2) higher than or equal to set point + LA1(2) + AFd if Att=rEL(ative)

***NOTE: if Att=rEL(ative) LAL must be negative: therefore set point+LAL<set point because set+(-|LAL|)=set-|LAL|**

Tab. 1 SET POINTS, Table of parameters and FUNCTIONS

*****NOTE: At level 1 the folders will only display all the level 1 parameters. At level 2 the folders will only display all the level 2 parameters.**

SET	DESCRIPTION	RANGE	DEFAULT*	VALUE**	LEVEL***	°C/°F
SP1	Set point 1	-LS1...HS1	0.0			
SP2	Set point 2	-LS2...HS2				
The Set points can be viewed from the machine status menu and not the programming menu. The range is determined by parameters LS1/2 and HS1/2.						
PAR.	DESCRIPTION	RANGE	DEFAULT*	VALUE**	LEVEL***	U.M.
CONTROLLER 1 (folder with "rE1" label)						
HC1	Regulating mode. If set to H, the controller operates in heating mode. If set to C, the controller operates in cooling mode.	H/C	H/C*		1	flag
OS1	Offset Set point 1	-100...100	0		2	°C/°F
db1	Regulation band 1 See ON-OFF regulation diagram	0...30.0	5		1	°C/°F
dF1	Relay 1 intervention differential. The load will stop when Set point 1 is reached (as indicated by the control probe) and will restart at a temperature equal to Set point 1 plus (or minus depending on HC1) the value of the differential. See ON-OFF regulation diagram	0.0...30.0	2		1	°C/°F
HS1	Maximum value for set point 1.	LS1..HdL	30		1	°C/°F
LS1	Minimum value for set point 1.	LdL..HS1	-50		1	°C/°F
CONTROLLER 1 PROTECTIONS (folder with "rE1" label)						
dn1	Start-up delay The specified time must elapse between the controller relay start-up request and actual start-up.	0...250	0		1	sec
do1	Delay after shut-down. The specified time must elapse between shut-down of controller relay and a subsequent start-up.	0...250	0		1	min
di1	Delay between start-ups. The specified time must elapse between two subsequent start-ups of the controller.	0...250	0		1	min
dE1	Shut-down delay. The specified time must elapse between the controller relay shut-down request and actual shut-down.	0...250	0		1	sec
NOTE: for parameters dn1, do1, di1, dE1 0= not active						
On1	Controller start-up time if probe is faulty. If set to "1" with Oft at "0" the controller is always on whereas if Oft >0 it operates in duty cycle mode. See Duty Cycle diagram	0...250	0		1	min
OF1	Controller shut-down time if probe is faulty. If set to "1" with Oft at "0" the controller is always off whereas if Oft >0 it operates in duty cycle mode. See Duty Cycle diagram	0...250	1		1	min
CONTROLLER 2 (folder with "rE2" label)						
HC2	Regulating mode. If set to H, the controller operates in heating mode. If set to C, the controller operates in cooling mode.	H/C	H/C*		1	flag
OS2	Offset Set point 2	-100...100	0		2	°C/°F
db2	Regulation band 2 See ON-OFF regulation diagram	0...30.0	4		1	°C/°F
dF2	Relay 2 intervention differential. The load will stop when the Set point is reached (as indicated by the control probe) and will restart at a temperature equal to Set point 2 plus (or minus depending on HC2) the value of the differential. See ON-OFF regulation diagram	0.0...30.0	2		1	°C/°F
HS2	Maximum possible set point value.	LS2..HdL	30		1	°C/°F
LS2	Minimum possible set point value.	LdL..HS2	-50		1	°C/°F
dn2	Delay in start-up of controller 2. See dn1	0...250	0		1	sec
do2	Delay after shut-down. The specified time must elapse between shut-down of controller 2 relay and a subsequent start-up.	0...250	0		1	min
di2	Delay between start-ups. The specified time must elapse between two subsequent start-ups of controller 2.	0...250	0		1	min
dE2	Delay in shut-down of controller 2. The specified time must elapse between the controller relay shut-down request and actual shut-down.	0...250	0		1	sec
NOTE: for parameters dn2, do2, di2, dE2 0= not active						
On2	Controller start-up time if probe is faulty. If set to "1" with Oft at "0" the controller is always on whereas if Oft >0 it operates in duty cycle mode. See Duty Cycle diagram	0...250	1		1	min
OF2	Controller shut-down time if probe is faulty. If set to "1" with Oft at "0" the controller is always off whereas if Oft >0 it operates in duty cycle mode. See Duty Cycle diagram	0...250	1		1	min
DEFROST CONTROLLER (folder with "dEF" label)						
dit	defrosting (compressor disabled). defrost interval time. Period of time elapsing between the start of two defrosting operations. 0= function disabled (defrost is NEVER performed)	0...250	6h		1	hours/min/sec (see dt1)
dt1	defrost time 1. Unit of measurement for defrost times ("dit" parameter). 0 = "dit" parameter expressed in hours. 1 = "dit" parameter expressed in minutes. 2 = "dit" parameter expressed in seconds.	0/1/2	0		2	num
dt2	defrost time 2. Unit of measurement for duration of defrosting ("dEt" parameter). 0 = "dEt" parameter expressed in hours. 1 = "dEt" parameter expressed in minutes. 2 = "dEt" parameter expressed in seconds. defrost Counting type. Selection of	0/1/2	1		2	num
dCt	defrosting time count mode. (see Par.dCt table) 0 = compressor operating hours (DIGIFROST® method); Defrosting active ONLY with compressor on. NOTE: compressor time of operation is counted irrespective of evaporator probe (counting is active if evaporator probe is absent or faulty). The value is ignored if RTC is enabled. 1 = Real Time - equipment operating hours; defrost counting is always active when the machine is on and starts at each power-on. 2 = compressor stop. Every time the compressor stops a defrost cycle is performed according to the dtY parameter	0/1/2	1		1	num
dOH	defrost Offset Hour. Start of-defrosting delay time from start-up of instrument.	0...59	0		1	min
dEt	defrost Endurance time. Defrosting time-out; determines maximum duration of defrosting.	1...250	30		1	min
dPO	defrost (at) Power On. Determines if the instrument must start defrosting at start-up (if the temperature measured by the evaporator allows this) y = yes, starts defrost at start-up; n = no, does not start defrost at start-up.	n/y	n		1	flag

PAR.	DESCRIPTION	RANGE	DEFAULT*	VALUE**	LEVEL***	U.M.
tcd	time compressor for defrost. Minimum time for compressor ON or OFF before defrost. If >0 (positive value) the compressor remains ACTIVE for tcd minutes; If <0 (negative value) the compressor remains INACTIVE for tcd minutes; If =0 the parameter is ignored.	-31...31	n		2	min
Cod	Compressor off (before defrost). Time for compressor OFF before defrost cycle. If a defrost cycle is set within the programmed time for this parameter, the compressor is not started up. If =0 function is stopped.	0...60	0		2	min
ALARMS (folder with "AL" label)						
Att	Alarm type. Parameter "HAL" and "LAL" modes, as absolute temperature values or as differential compared to the Set point. 0 = absolute value; 1 = relative value.	0/1	0		1	flag
AFd	Alarm differential.	1.0...50.0	3.0		1	°C/°F
HAL	Maximum alarm. Temperature limit (whose absolute or relative value status is regulated by "Att") above which the alarm is activated	LAL...150.0	50.0		1	°C/°F
LAL	Minimum alarm. Temperature limit (whose absolute or relative value status is regulated by "Att"). below which, the alarm is activated	-50.0...HAL	-50.0		1	°C/°F
PAO	Power-on Alarm Override. Alarm exclusion time after instrument start-up, after a power failure.	0...10	0		1	hours
dAO	defrost Alarm Override.	0...999	0		1	min
tdO	Alarm signal delay time out door Open. Time out after alarm signal following digital input disabling (door open).	0...250	0		1	min
tAO	temperature Alarm Override. Temperature alarm signal delay time.	0...250	1		1	min
dAt	defrost Alarm time. Alarm signal for defrost end due to time-out. n = does not activate alarm; y = activates alarm.	n/y	n		2	flag
EAL	External Alarm Lock. External alarm to lock controllers (n=does not lock, y=locks).	n/y	n		2	flag
DISPLAY (folder with "dis" label)						
LOC	Keyboard locked (set point and buttons). However, you can still access the parameter programming menu and modify parameters including the status of this parameter to allow keyboard unlocking. y = yes; n = no.	n/y	n		1	flag
PA1	Password 1. When enabled (value is not 0) it represents the access key to level 1 parameters.	0...250	0		1	num
PA2****	Password 2. When enabled (value is not 0) it represents the access key to level 2 parameters.	0...250	0		2	num
ndt	number display type. Display with decimal point. y = yes; n = no.	n/y	y		1	flag
CA1	CAlibration 1. Calibration 1. Positive or negative temperature value added to the value read by probe 1, based on "CA" parameter settings.	-12.0...12.0	0		1	°C/°F
CA	CAlibration Intervention. Intervention on view offset, thermostat control offset or both. 0 = only modifies the temperature displayed; 1 = adds to the temperature used by controllers, not the temperature displayed that remains unchanged; 2 = adds to temperature displayed that is also used by controllers.	0/1/2	2		2	num
LdL	Low display Label. Minimum value the instrument is able to display.	-55.0...302	-55.0		2	°C/°F
HdL	High display Label. Maximum value the instrument is able to display.	-55.0...302	140.0		2	°C/°F
ddl	defrost display Lock. Display mode during defrosting. 0 = displays the temperature read by the thermostat control probe; 1 = locks the reading on the temperature value read by thermostat control probe when defrosting starts until the next time the Set point value is reached; 2 = displays the label "deF" during defrosting until the next time the Set point value is reached.	0/1/2	1		1	num
dro (°)	display read-out. Select °C or °F to display temperature read by probe. 0 = °C, 1 = °F. N. B: switching from °C to °F DOES NOT modify set points, differentials, etc. (for example set point=10°C becomes 10°F). Selection of the value type to be displayed.	0/1	0		1	min
ddd	0 = Set point; 1 = probe 1 (thermostat control); 2 = NOT USED 3 = NOT USED	0/1/2	1		2	num
rHC	running Hours Cooling output. Cooling operating hours counter	0...1999	0		1	num
rHH	running Hours Heating output. Heating operating hours counter	0...1999	0		1	num
CONFIGURATION (folder with "CnF" label)						
H00(1)()	For selection of probe type, PTC or NTC.	0/1	0/1 (1)		1	flag
H01	Output link. 0 = independent; 1 = dependent; 2 = Neutral Zone (or window)	0/1/2	2 (Neutral Zone)		2	num
H02	Button activation time if buttons are configured for a second function. For the ESC, Up and DOWN buttons configured for a second function (defrost, aux, etc) the time for rapid enabling is set. Aux is an exception and has a set time of 1 second	0...15	5		2	sec
H03	Parameter that defines the relay to be deactivated if defrosting is effected 0=disabled; 1=controller 1; 2=controller 2; 3=controller 1-2	0/1/2/3	3		1	num
H10	Output delay from power-on. Attention! If = 0 it is not active; if ≠ 0 output will not be activated before time expires	0...250	0		2	sec
H11	Configuration of digital inputs/polarity 0 = Disabled; 1 = Defrost; 2 = Reduced set point 1 and 2; 3 = NOT USED; 4 = Door switch; 5 = External alarm; 6 = H/C mode;	-6...6	6		2	num

PAR.	DESCRIPTION	RANGE	DEFAULT	VALUE**	U.M.
rEL	Device version. Read only parameter.	/	/		/
tAb	Reserved. Read only parameter.	/	/		/
	COPY CARD (folder with "Fpr" label)				
UL	UpLoad: transfer of programming parameters from instrument to Copy Card.	/	/		/
dL	downLoad: transfer of programming parameters from Copy Card to instrument.	/	/		/
Fr	Format. Cancels all data entered in the copy card.				/

PLEASE NOTE: if "Fr" parameter (formatting of copy card) is used the data entered in the/card will be permanently lost. This operation cannot be undone. After the operation with the Copy Card the controller must be switched off and then switched back on

- (1) Check the NTC/PTC default probe type installed (see label)
- (2) Refers exclusively to high and low temperature alarms

* DEFAULT column: for parameters HC1, HC2 the default depends on the model.
 ** VALUE column: to be compiled manually with any custom settings (if different from default value).
 *** LEVEL column: indicates the visibility level of parameters accessed using a PASSWORD (see relevant paragraph)
 **** PA2 is visible (or will be requested, if specified) at level 1 **in the CnF folder** and can be set (modified) at level 2 **in the diS folder**

(!) WARNING!

- If one or more parameters marked with (!) are modified, the controller must be switched off after the modification and then switched back on
- **PLEASE NOTE:** We strongly recommend that you switch the instrument off and on again each time parameter configuration is changed in order to prevent malfunctioning of the configuration and/or ongoing timings.

FUNCTIONS (folder with "FnC" label)The FnC folder (last folder visible from the Programming Menu) contains several functions that are activated using the "set" button
SEE FUNCTIONS paragraph

label PA2
 In the CnF folder you can access all level 2 parameters from label PA2 by pressing the "set" button
SEE paragraph 2) Displaying level 2 parameters

(*) The mathematical conversion for temperature is $^{\circ}\text{F} = (9/5) * ^{\circ}\text{C} + 32$. For example: $32^{\circ}\text{F} = 0^{\circ}\text{C}$; $50^{\circ}\text{F} = 10^{\circ}\text{C}$.

dro parameter: when changing from $^{\circ}\text{C}$ to $^{\circ}\text{F}$ or vice versa the mathematical conversion is NOT performed and the set point values, differentials, etc. are NOT modified. All the temperature values set will therefore need reviewing. e.g. with a set point set to 10°C , when changing the value to $^{\circ}\text{F}$ the set point will become 10°F and not 50°F (according to the conversion table)

WIRING DIAGRAMS

TERMINALS

1 - 2	N.O. relay output regulator 1 Out1 HEATING
1 - 3	N.C. relay output regulator 1 Out1 HEATING
4 - 5	N.O. relay output regulator 2 Out2 COOLING
6 - 7	Power supply 3W max.
8 - 10	Probe Input Pb1 (thermostat)
8 - 11	Digital Input (D.I.)
A	TTL input for connection to Copy Card

NOTE:

- Default load settings
- all outputs are parameter-configurable
- for relay capacity, see label on instrument.

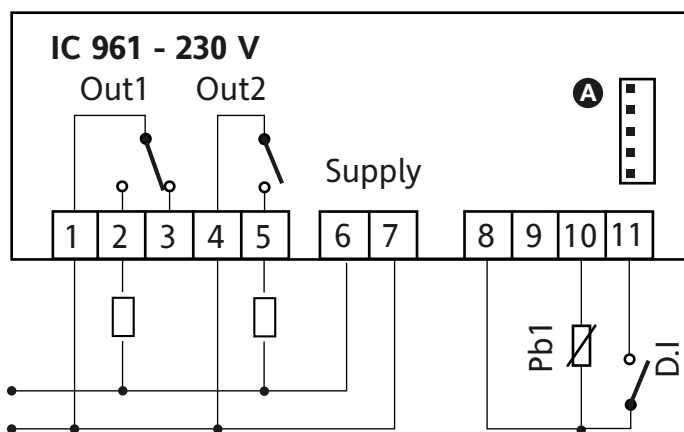
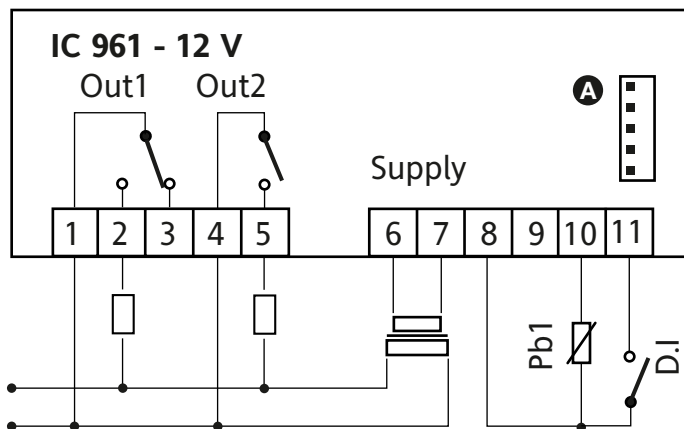

Eliwell & Controlli s.r.l.
 Via dell'Industria, 15 Zona Industriale Paludi
 32010 Pieve d'Alpago (BL) ITALY
 Telephone +39 0437 986111
 Facsimile +39 0437 989066
 Internet <http://www.eliwell.it>

Technical Customer Support:
 Email: techsuppeliwell@invensys.com
 Telephone +39 0437 986300

Climate Controls Europe
An Invensys Company

10/2004 eng
 cod. 9IS23093

